

FieldLazer™ ES100

For application of water-based field striping materials. For professional use only. Not approved for use in explosive atmospheres or hazardous (classified) locations.



Important Safety Instructions

Read all warnings and instructions in this manual before using the equipment. Be familiar with the proper control and usage of the equipment. Save these instructions.

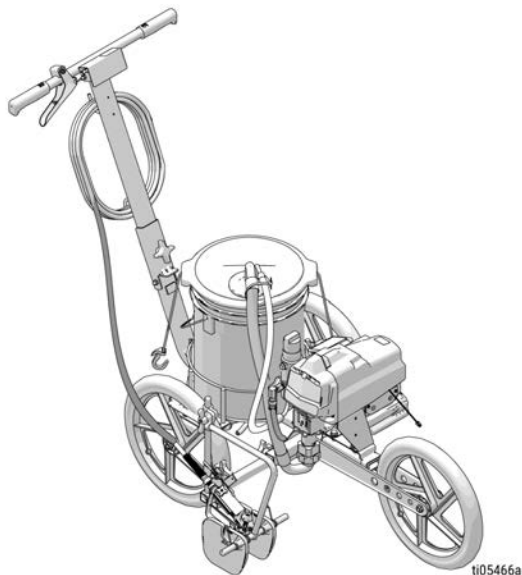

ti05466a



graco.com/contact

CONTENTS



| | |
|----------------------------------|-----------|
| Models | 3 |
| Related Manuals | 4 |
| Translated Manuals | 4 |
| Safety Symbols | 5 |
| Warnings | 6 |
| Technical Specifications | 9 |
| Component Identification | 11 |
| Pressure Relief Procedure | 13 |
| Setup | 14 |
| Strain the Paint | 16 |
| Battery Installation and Removal | 16 |
| Operation | 17 |
| Prime/Spray Valve | 17 |
| Flush Storage Fluid | 17 |
| Fill Pump | 19 |
| Fill Gun and Hose | 20 |
| Spray Tip Installation | 21 |
| Spray | 23 |
| Stencil Spraying | 24 |
| Spray Tip Selection | 25 |
| Clear Tip Clog | 26 |
| Digital Display | 27 |
| Cleanup | 32 |
| FastFlush | 35 |
| Clean the Gun | 36 |
| Maintenance | 37 |
| Recycling and Disposal | 38 |
| End of Product Life | 38 |
| Troubleshooting | 39 |
| FieldLazer™ ES100 Parts | 46 |
| Electrical Schematic | 57 |
| California Proposition 65 | 59 |

MODELS

The part numbers reflect distinct features and characteristics of the FieldLazer™ ES100.

FIELDLAZER™ ES100 MODELS AND APPROVALS

Maximum Working Pressure: 1750 psi (12.1 MPa, 121 bar)

| MODEL | APPROVALS |
|-------------------|---|
| 26U003 NA | |
| 26U004 EMEA/UK |  |
| 26U005 ANZ/AP |  |

The FieldLazer ES100 is compatible with the following DEWALT® FLEXVOLT® 54 V and 60 V batteries:

- DCB606 - 60 V/2 Ah (20 V/6 Ah)
- DCB546 - 54 V/2 Ah (18 V/6 Ah)
- DCB609 - 60 V/3 Ah (20 V/9 Ah)
- DCB547 - 54 V/3 Ah (18 V/9 Ah)
- DCB548 - 54 V/4 Ah (18 V/12 Ah)
- DCB612 - 60 V/4 Ah (20 V/12 Ah)

RELATED DEWALT MANUALS

| MANUAL | DESCRIPTION | REGION |
|--------------------|---|--------|
| N463494 | DEWALT DCB118 Fast Charger Manual | USA/CA |
| N463510 N463511 | DEWALT DCB118-QW Fast Charger Manual (Part 1 and 2) | EMEA |
| N501136 | DEWALT DCB118-XE Fast Charger Manual | ANZ/AP |

RELATED MANUALS

Additional documents are available to support the operation, repair, and maintenance of the FieldLazer™ ES100. Find English manuals and any available translations at www.graco.com.

Table 2-1: Related Manuals for FieldLazer™ ES100 Operation Manual X045758

| ENGLISH MANUAL | DESCRIPTION |
|----------------|--|
| 312830 | SG2™, SG3™ Spray Guns, Instructions, Parts |
| 334599 | ProConnect® Endurance® Displacement Pump, Repair |

TRANSLATED MANUALS

Additional language documents are available to support all regions where the FieldLazer™ ES100 is sold. Find any available translations at www.graco.com.

Table 2-2: Translations for FieldLazer™ ES100 Operation Manual

| LANGUAGE | MANUAL NUMBER |
|----------|---------------|
| Chinese | X045758ZH |
| English | X045758EN |
| French | X045758FR |
| German | X045758DE |
| Korean | X045758KO |
| Spanish | X045758ES |

SAFETY SYMBOLS

The following safety symbols appear throughout this manual and on warning labels. Read the table below to understand what each symbol means.

| SYMBOL | MEANING |
|--|--|
|  | Equipment Misuse Hazard |
|  | Fire and Explosion Hazard |
|  | Warning |
|  | Moving Parts Hazard |
|  | Skin Injection Hazard |
|  | Skin Injection Hazard |
|  | Splash Hazard |
|  | Toxic Fluid or Fumes Hazard |
|  | Do Not Place Hands or Other Body Parts Near Fluid Outlet |

| SYMBOL | MEANING |
|--|---|
|  | Do Not Put Hand in Front of Spray Tip |
|  | Do Not Stop Leaks with Hand, Body, Glove or Rag |
|  | Do Not Use Flammable Materials |
|  | Follow Pressure Relief Procedure |
|  | Read Manual |
|  | Ventilate Work Area |
|  | Wear Personal Protective Equipment |



Safety Alert Symbol

This symbol indicates: Attention! Become Alert! Look for this symbol throughout the manual to indicate important safety messages.

WARNINGS

The following warnings apply throughout this manual. Read, understand, and follow the warnings before using this equipment. Failure to follow these warnings can result in serious injury.

WARNING



SKIN INJECTION HAZARD

High-pressure spray is able to inject toxins into the body and cause serious injury that can result in amputation. In the event that injection occurs, **get immediate surgical treatment.**



- Do not aim the gun at, or spray, any person or animal.
- Keep hands and other body parts away from the discharge. For example, do not try to stop leaks with any part of the body.
- Always use the spray tip guard. Do not spray without spray tip guard in place.
- Use Graco spray tips.
- Use caution when cleaning and changing spray tips. In the case where the spray tip clogs while spraying, follow the **Pressure Relief Procedure** for turning off the unit and relieving the pressure before removing the spray tip to clean.
- Equipment maintains pressure after power is turned off. Do not leave the equipment energized or under pressure while unattended. Follow the **Pressure Relief Procedure** when the equipment is unattended or not in use, and before servicing, cleaning, or removing parts.
- Check hoses and parts for signs of damage. Replace any damaged hoses or parts.
- This system is capable of producing 1750 psi (121 bar, 12.1 MPa). Use Graco parts or accessories that are rated a minimum of 1750 psi (121 bar, 12.1 MPa).
- Always engage the trigger lock when not spraying. Verify the trigger lock is functioning properly.
- Verify that all connections are secure before operating the unit.
- Know how to stop the unit and bleed pressure quickly. Be thoroughly familiar with the controls.



FIRE AND EXPLOSION HAZARD

Flammable fumes, such as solvent and paint fumes, **in work area** can ignite or explode. To help prevent fire and explosion:



- Do not spray or clean with flammable materials. Use water-based materials only.
- Use equipment only in well-ventilated area.
- Keep work area free of debris, including solvent, rags and gasoline.
- Keep a working fire extinguisher in the work area.



WARNING



EQUIPMENT MISUSE HAZARD

Misuse can cause death or serious injury.

- Always wear appropriate gloves, eye protection, and a respirator or mask when painting.
- Do not operate or spray near children. Keep children away from equipment at all times.
- Do not overreach or stand on an unstable support. Keep effective footing and balance at all times.
- Stay alert and watch what you are doing.
- Do not operate the unit when fatigued or under the influence of drugs or alcohol.
- Do not kink or overbend the hose.
- Do not expose the hose to temperatures or to pressures in excess of those specified by Graco.
- Do not use the hose as a strength member to pull or lift the equipment.
- Do not spray with a hose shorter than 25 feet (7.6 m).
- Do not alter or modify equipment. Alterations or modifications may void agency approvals and create safety hazards.
- Make sure all equipment is rated and approved for the environment in which you are using it.



PRESSURIZED ALUMINUM PARTS HAZARD

Use of fluids that are incompatible with aluminum in pressurized equipment can cause serious chemical reaction and equipment rupture. Failure to follow this warning can result in death, serious injury, or property damage.

- Do not use 1,1,1-trichloroethane, methylene chloride, other halogenated hydrocarbon solvents or fluids containing such solvents.
- Do not use chlorine bleach.
- Many other fluids may contain chemicals that can react with aluminum. Contact your material supplier for compatibility.



BATTERY AND CHARGER COMPATIBILITY HAZARD

Only use DEWALT brand 54 V Max or 60 V Max batteries and battery chargers with this tool.



- READ ALL INSTRUCTIONS included with this sprayer regarding the safety and usage of DEWALT batteries and battery chargers.
- Do not wash or spray down battery.
- Do not clean the battery with anything other than a cloth moistened with water.

 **WARNING**



MOVING PARTS HAZARD

Moving parts can pinch, cut, or amputate fingers and other body parts.



- Keep clear of moving parts.
- Do not operate equipment with protective guards or covers removed.
- Equipment can start without warning. Before checking, moving, or servicing equipment, follow the **Pressure Relief Procedure** and disconnect all power sources.



TOXIC FLUID OR FUMES HAZARD

Toxic fluids or fumes can cause serious injury or death if splashed in the eyes or on skin, inhaled, or swallowed.

- Read Safety Data Sheets (SDSs) to know the specific hazards of the fluids you are using.
- Store hazardous fluid in approved containers, and dispose of it according to applicable guidelines.



PERSONAL PROTECTIVE EQUIPMENT

Wear appropriate protective equipment when in the work area to help prevent serious injury, including eye injury, hearing loss, inhalation of toxic fumes, and burns. Protective equipment includes but is not limited to:

- Protective eyewear and hearing protection.
- Respirators, protective clothing, and gloves as recommended by the fluid and solvent manufacturer.

TECHNICAL SPECIFICATIONS

The table provides important information related to the FieldLazer™ ES100, including product attributes, measurements, and performance characteristics that support the use of the equipment.

Table 5-1: Technical Specifications for FieldLazer™ ES100

| | US | METRIC |
|----------------------------------|--|-------------------|
| Sprayer | | |
| Maximum Fluid Working Pressure | 1750 psi | 12.1 MPa, 121 bar |
| Maximum Delivery* | 0.48 gpm | 1.8 lpm |
| Maximum Tip Size | 0.021 in. | 0.533 mm |
| Fluid Outlet npsm | 1/4 in. | |
| Power Requirements | See Battery Installation and Removal | |
| Dimensions | | |
| Height | 48 in. | 121 cm |
| Length | 24 in. | 61 cm |
| Width | 24 in. | 61 cm |
| Weight (with battery) | 80 lb | 36.32 kg |
| Storage Temperature Range ♦ ❖ | -30° to 160°F | -35° to 71°C |
| Operating Temperature Range ✓ | 40° to 115°F | 4° to 46°C |
| Noise | | |
| Sound Pressure | 83 dBa** | |
| Sound Power | 93 dBa** | |
| Materials of Construction | | |
| Wetted Material on all Models | Stainless steel, brass, leather, ultra-high molecular weight polyethylene (UHMWPE), carbide, nylon, aluminum, polypropylene, fluoroelastomer, PTFE, zinc-and nickel-plated carbon, steel, acetal, polyethylene, urethane, rubber | |
| Notes | | |

TECHNICAL SPECIFICATIONS

| | US | METRIC |
|---|----|--------|
| <p><i>* Startup pressures and displacement per cycle may vary based on suction condition, discharge head, air pressure, and fluid type.</i></p> <p><i>** Sound pressure measured 3 feet (1 meter) from equipment. Sound power measured per ISO-3744.</i></p> <ul style="list-style-type: none">◆ When pump is stored with non-freezing fluid. Pump damage will occur if water or latex paint freezes in pump.❖ Damage to plastic parts may result if impact occurs in low temperature conditions.✓ Changes in paint viscosity at very low or very high temperatures can affect sprayer performance. <p>All trademarks or registered trademarks are the property of their respective owners.</p> | | |

COMPONENT IDENTIFICATION

The diagram highlights the controls and features on the FieldLazer™ ES100 that are used during typical operation.

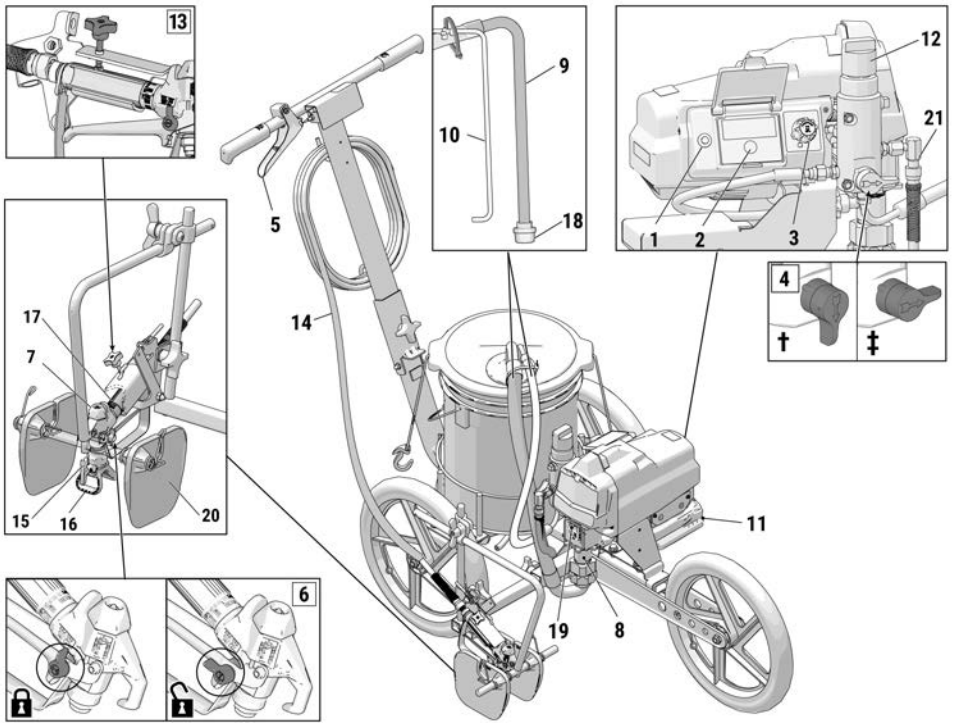

ti05467a

Figure 6-1: FieldLazer™ ES100 Diagram

COMPONENT IDENTIFICATION

KEY

| | |
|----|--|
| 1 | Power Button |
| 2 | Display Button |
| 3 | Pressure Control |
| 4 | Prime Valve |
| † | Prime |
| ‡ | Spray |
| 5 | Spray Gun Control Lever |
| 6 | Trigger Lock |
| 7 | Airless Spray Gun |
| 8 | Pump |
| 9 | Suction Tube |
| 10 | Drain Tube |
| 11 | Battery Port |
| 12 | Striper Fluid Filter Access |
| 13 | Gun Retainer Knob |
| 14 | Airless Hose |
| 15 | Reversible Spray Tip |
| 16 | Tip Guard |
| 17 | Gun Fluid Filter (optional, located in handle) |
| 18 | Fluid Intake Strainer |
| 19 | Finger Guard / TSL™ Fill Point |
| 20 | Spray Shield |
| 21 | Fluid Outlet |

PRESSURE RELIEF PROCEDURE

Relieve pressure on the FieldLazer™ ES100 when operation is stopped, and before cleaning, checking, or servicing the equipment.



Follow the Pressure Relief Procedure whenever you see this symbol.



This equipment stays pressurized until pressure is manually relieved. To help prevent serious injury from pressurized fluid, such as skin injection or splashed fluid and moving parts, follow **Pressure Relief Procedure** whenever striper is stopped and before striper is cleaned or checked, and before equipment is serviced.

1. Engage the Trigger Lock. Always engage the Trigger Lock when the FieldLazer is stopped to prevent the Airless Spray Gun from being triggered accidentally.

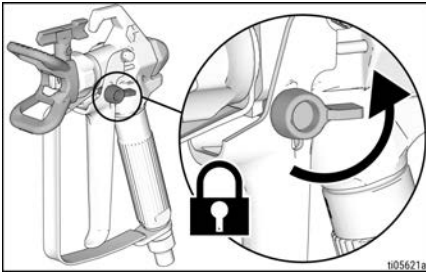

2. Turn Power Button to the **OFF** position. Power button is not illuminated when power is OFF.

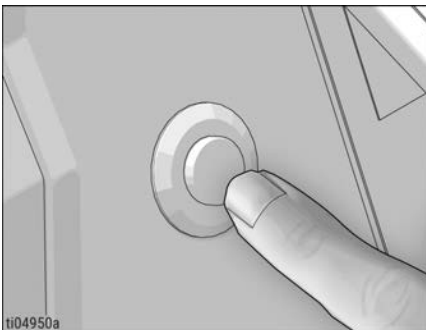

3. Turn Pressure Control knob to lowest setting.

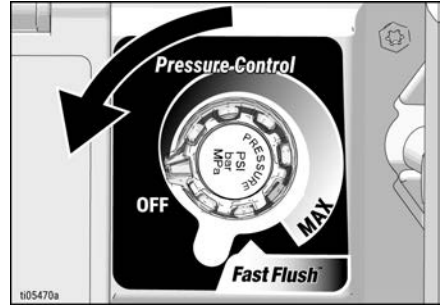

4. Hold the Airless Spray Gun firmly to a pail, point Airless Spray Gun into pail. Disengage the Trigger Lock and trigger the Airless Spray Gun to relieve pressure.



5. Engage the Trigger Lock.
6. Put Drain Tube into a pail and place Prime Valve in the prime position (drain) to relieve pressure.
7. If you suspect the Reversible Spray Tip or hose is clogged or that pressure has not been fully relieved:
 - a. Using a wrench **VERY SLOWLY** loosen the spray tip guard retaining nut or the hose end coupling to relieve pressure gradually.
 - b. Using a wrench loosen the nut or coupling completely.
 - c. Clear Airless Hose or Reversible Spray Tip obstruction.

SETUP

When using the equipment for the first time or after long-term storage, follow the steps to prepare the FieldLazer™ ES100 for operation.

When unpacking FieldLazer for the first time or after long-term storage perform setup procedure.

1. Remove FieldLazer from box. Unfold handle.

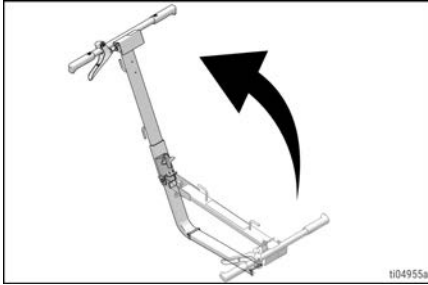

2. Tighten knob and secure handle in place.

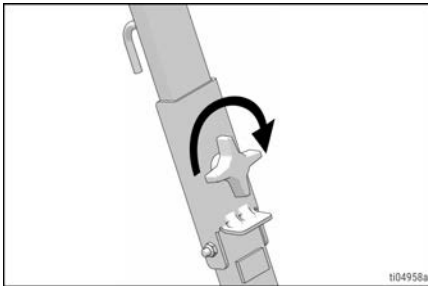

3. Assemble Spray Shields to striper.

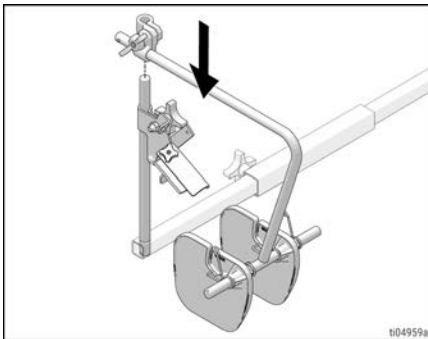

4. Loosen knob and slide Airless Spray Gun outside of wheel. Tighten knob.

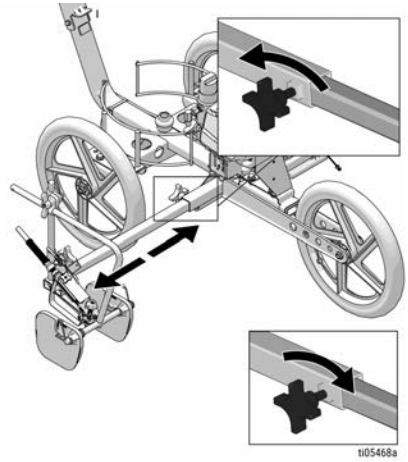

5. Fill throat packing nut with Throat Seal Liquid (TSL™) to prevent premature packing wear. Do this daily or each time you spray.

- a. Place the TSL bottle nozzle into the top center opening in the grill at the front of the sprayer.
- b. Squeeze bottle to dispense enough TSL to fill the space between the pump rod and packing nut seal.

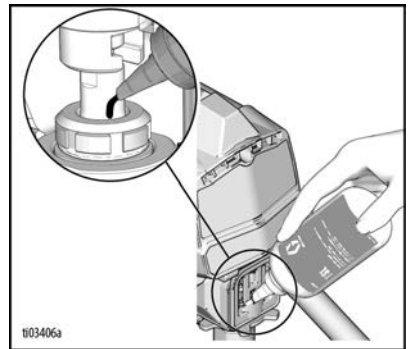

SETUP

6. Ensure Tip Guard and Reversible Spray Tip are removed. Do not lose seal.

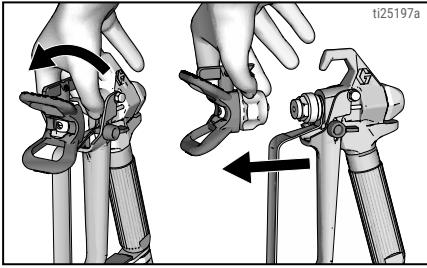

7. Place Drain Tube in waste pail.

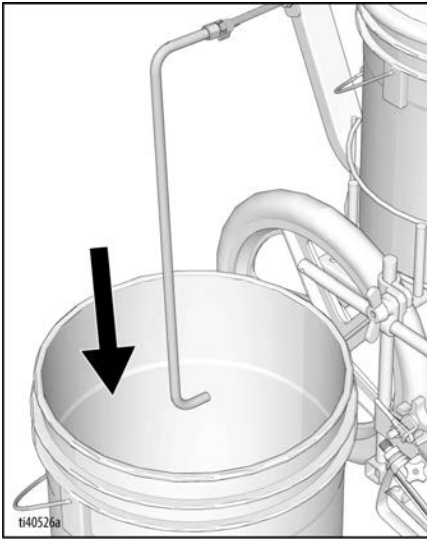

8. When unpacking the FieldLazer for the first time, remove packaging materials from Fluid Intake Strainer. After long-term storage, check Fluid Intake Strainer for clogs and debris.

9. Place Suction Tube in water pail.

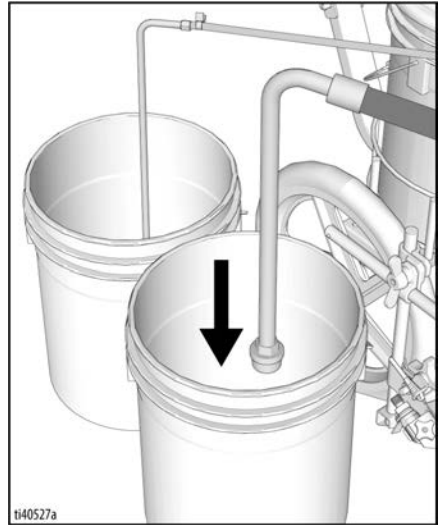

10. Turn Prime Valve down.

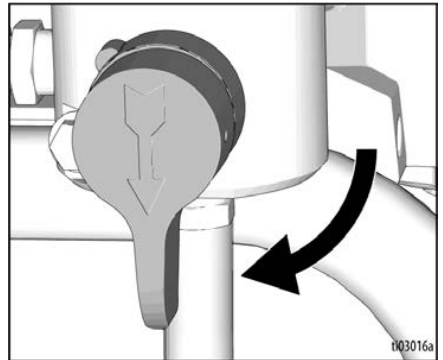

11. Turn Pressure Control knob all the way left (counterclockwise) to minimum pressure.



STRAIN THE PAINT

Previously opened paint may contain dried paint or other debris. Strain the paint before using to avoid priming problems and spray tip clogs. Paint strainers are available where paint is sold. Stretch a paint strainer over a clean pail and pour the paint through the strainer to capture any dried paint and debris before spraying.



BATTERY INSTALLATION AND REMOVAL

Always start with a fully charged battery. Do not splash or immerse battery or charger in water. See battery and charger information shipped with the FieldLazer.

Remove and install battery into the FieldLazer as follows:

1. Remove the battery if in place.

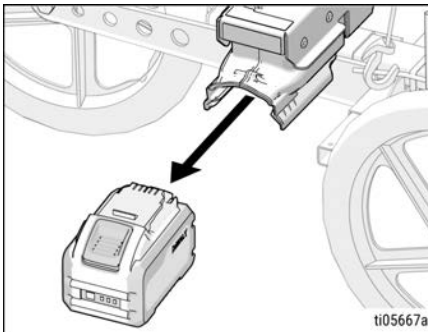

2. Install battery by aligning the battery pack with the rails inside the FieldLazer. Slide battery pack in until it is firmly seated. Ensure battery pack does not disengage.

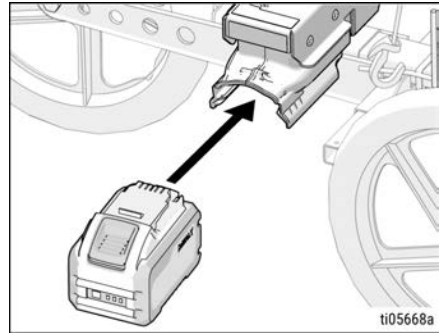

OPERATION

The instructions provide guidance on how to use the FieldLazer™ ES100.

PRIME / SPRAY VALVE

The Prime Valve uses a lever that is flipped between the prime and spray position.

SPRAY POSITION

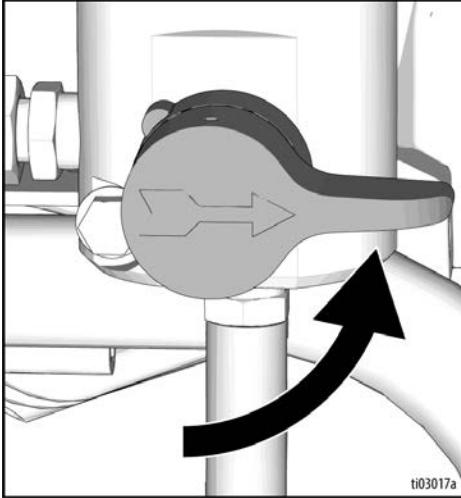

PRIME POSITION

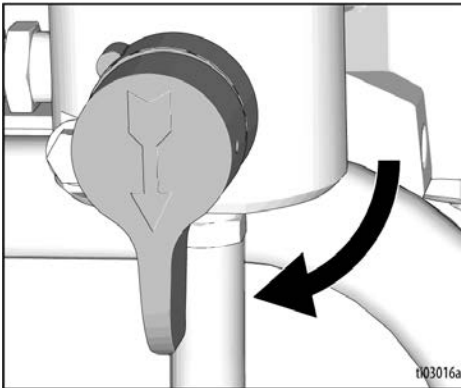

FLUSH STORAGE FLUID

The FieldLazer arrives from the factory with Pump Armor™ in the system. **Flush the Pump Armor from the sprayer before using it for the first time.**

1. Perform **Pressure Relief Procedure**.

2. Make certain Power Button is **OFF**. Power button is not illuminated when OFF.

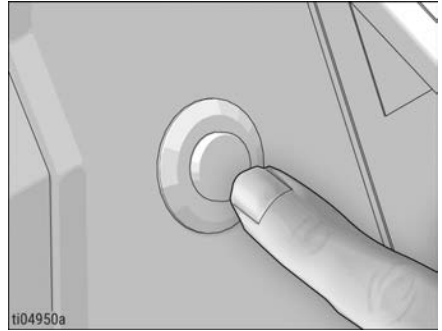

- a. Separate Drain Tube (smaller) from Suction Tube (larger).

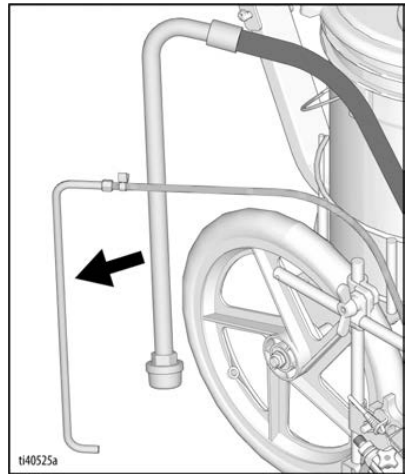

OPERATION

b. Place Drain Tube in waste pail.

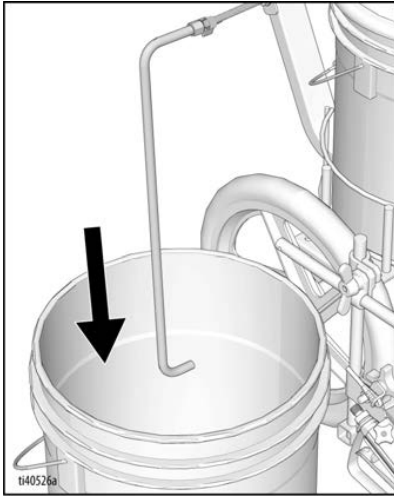

c. Submerge Suction Tube in a grounded pail partially filled with water or flushing fluid.

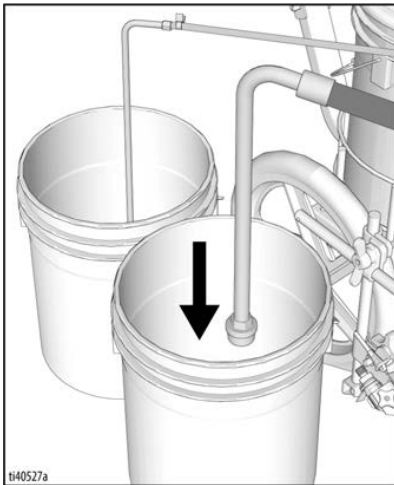

3. Place Prime Valve in prime position.

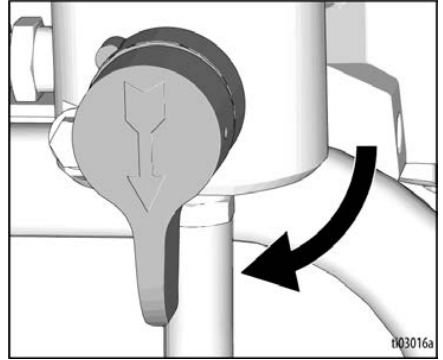

4. Install battery. See **Battery Installation and Removal**.

5. Align setting indicator with low setting on Pressure Control knob.

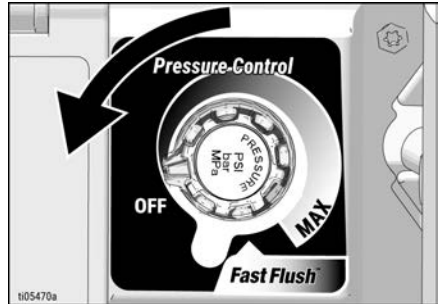

6. Turn Power Button to **ON** position. Power Button is illuminated when **ON**.

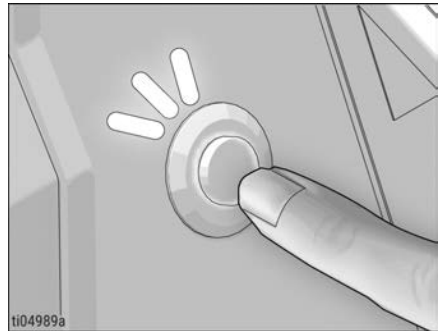



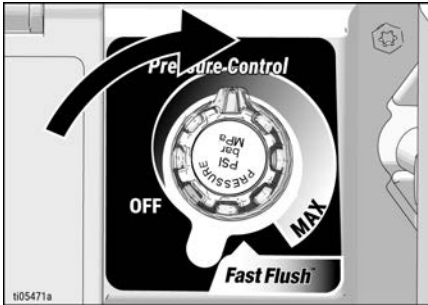

- Increase pressure 1/2 turn to start motor. Allow paint or other material to circulate through the FieldLazer until material flows out the Drain Tube.

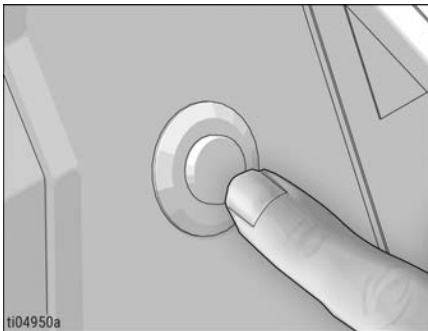

- When the FieldLazer starts pumping, flushing fluid and air bubbles will be purged from the system. Allow fluid to flow out of Drain Tube into waste pail for 30 to 60 seconds.
- Turn Power Button to **OFF** position. Power Button is not illuminated when OFF.



|  WARNING | | | |
|--|---|---|---|
|  |  |  |  |
| <p>High-pressure spray is able to inject toxins into the body and cause serious bodily injury. Do not stop leaks with hand or rag.</p> | | | |

- Inspect for leaks. If leaks occur, perform **Pressure Relief Procedure** then tighten all fittings. If there are no leaks, continue with the next step.

FILL PUMP

- Move Suction Tube to paint pail and submerge Suction Tube in paint.



- Press Power Button to **ON** position. Power Button is illuminated when power is ON.
- Wait to see paint coming out of the Drain Tube.



- Press Power Button to **OFF** position. Power Button is illuminated when power is OFF.

F I L L G U N A N D H O S E

1. Hold Airless Spray Gun against waste pail. Point Airless Spray Gun into waste pail.
 - a. Loosen Gun Retainer Knob and remove Airless Spray Gun from holder.
 - b. Disengage Trigger Lock.
 - c. Pull and hold Airless Spray Gun trigger.
 - d. Turn Prime Valve to spray position.
 - e. Press Power Button to **ON** position. Power Button is illuminated when power is ON.

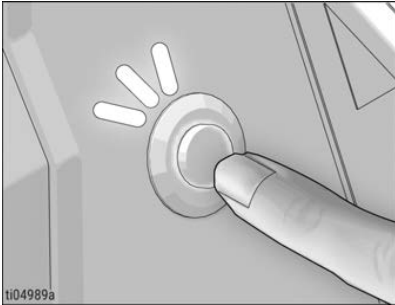

2. Continue to trigger Airless Spray Gun into waste pail until only paint comes out of the Airless Spray Gun.
3. Release trigger. Engage Trigger Lock.

4. Transfer Drain Tube to paint pail.



NOTE:

When motor stops, the FieldLazer is ready to paint. If motor continues to run, the FieldLazer is not properly primed. Repeat **Fill Pump** and **Fill Gun and Hose**.

SPRAY TIP INSTALLATION

Properly install and remove a spray tip on the ES100 Standard FieldLazer.

| WARNING | | | | |
|--|---|---|---|---|
|  |  |  |  |  |
| <p>To avoid serious injury from skin injection, do not put your hand in front of the Spray Tip when installing or removing the Spray Tip or Spray Tip Guard.</p> | | | | |

To prevent Reversible Spray Tip leaks, ensure proper installation of Reversible Spray Tip and Tip Guard.

1. Perform **Pressure Relief Procedure**.
2. Engage Trigger Lock.
3. Loosen Gun Retaining Knob and remove Airless Spray Gun from holder.

4. Verify Reversible Spray Tip and Tip Guard parts are assembled in the order shown.

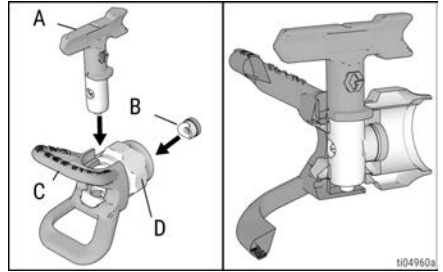

- a. Use Reversible Spray Tip to align gasket and seal in the Tip Guard.

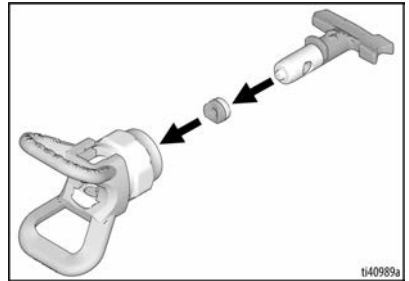

- b. Reversible Spray Tip must be pushed all the way into the Tip Guard. Turn Reversible Spray Tip to push down.

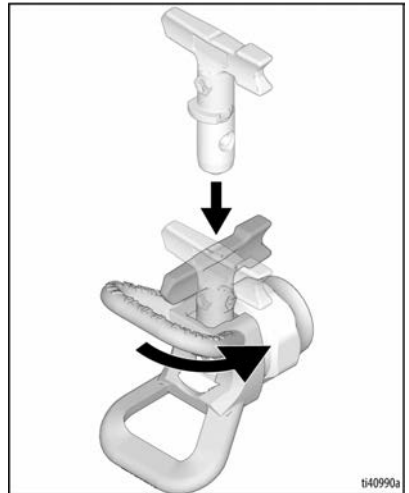

- c. Turn the arrow-shaped handle on the Reversible Spray Tip forward to the spray position.

OPERATION

5. Screw spray tip assembly onto the Airless Spray Gun and tighten.

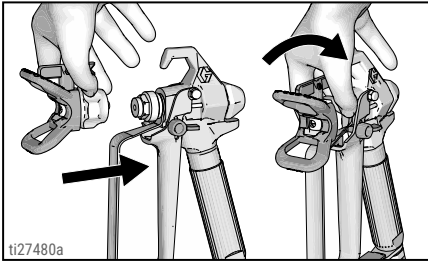

6. Return Airless Spray Gun to holder.

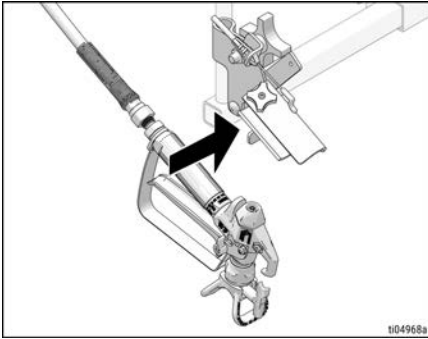

7. Place trigger guard in front of nut on gun holder. Tighten knob.

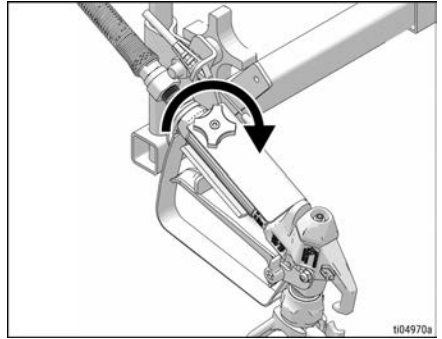
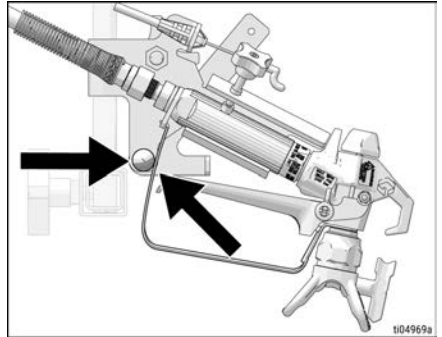

SPRAY

1. Adjust Spray Shields for desired width.

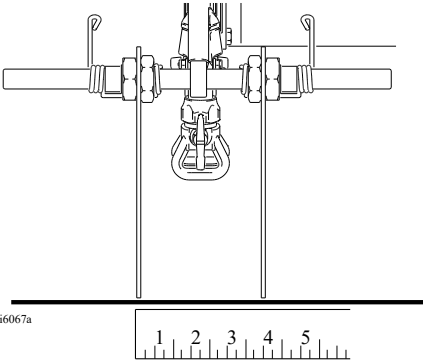

2. Grasp Spray Shield with one hand and squeeze spring arms with the other hand.

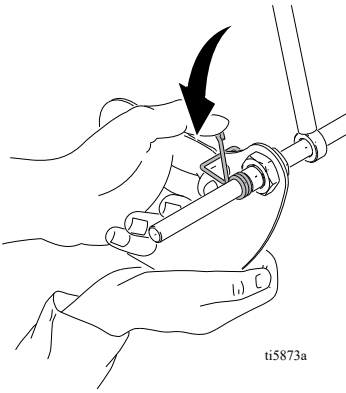

3. Slide Spray Shield to desired position and release spring.

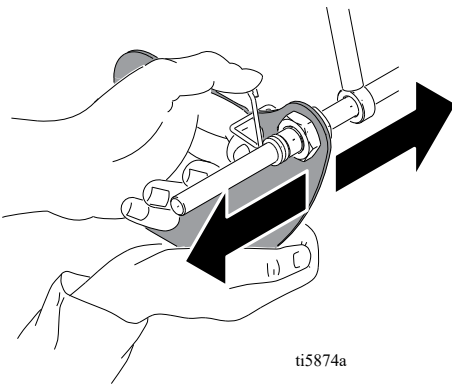

4. Squeeze Spray Gun Control Lever and push striper forward to spray a test stripe.

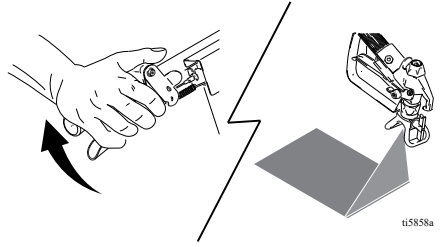

5. Adjust Airless Spray Gun height so paint spray strikes shields 1/4 in. from bottom of Spray Shields.

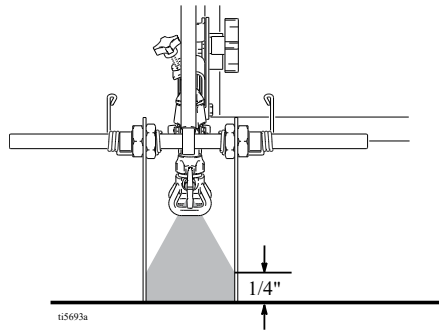

6. Loosen knob.

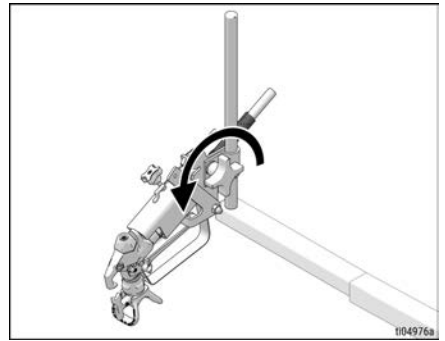

OPERATION

7. Slide Airless Spray Gun up or down.

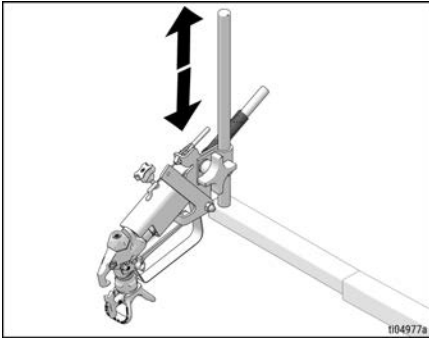

2. Remove Airless Spray Gun from holder.

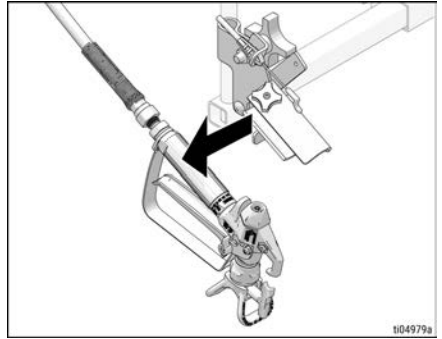

8. Spray a test stripe before spraying the actual field.

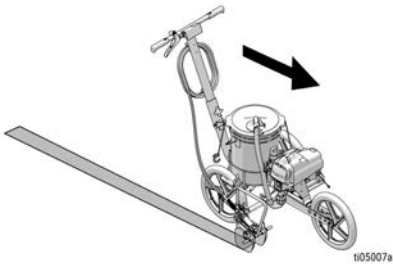

3. Trigger Airless Spray Gun over stencil pattern.

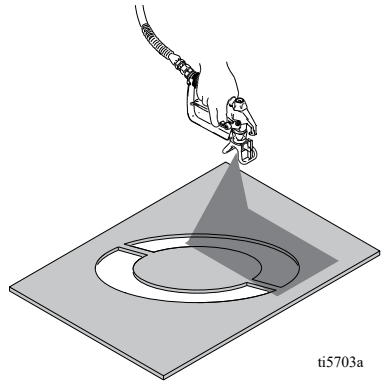

STENCIL SPRAYING

1. Loosen Gun Retainer Knob.

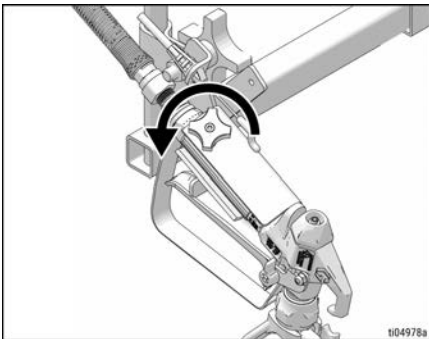

4. Return Airless Spray Gun to holder.

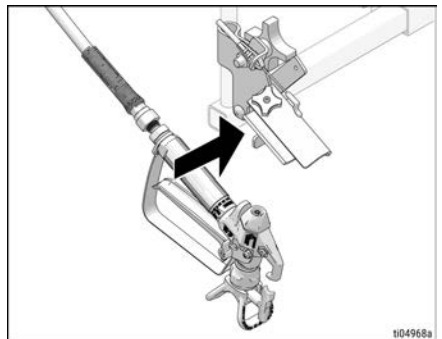

5. Tighten Gun Retainer Knob.

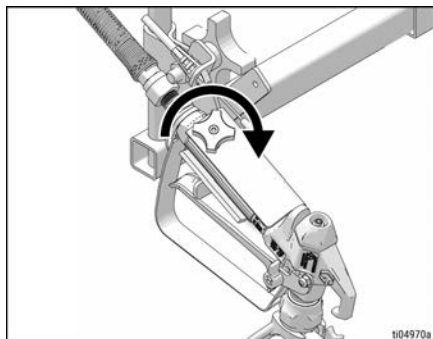
**SPRAY TIP SELECTION****SELECTING TIP SIZE**

Reversible Spray Tips come in a variety of hole sizes for spraying a range of fluids. Your FieldLazer includes a tip for use in most paint spraying applications.

Hints:

- As you spray, the tip wears and enlarges. Starting with a tip hole size smaller than the maximum will allow you to spray within the rated flow capacity of the sprayer.
- Use larger tip hole size with thicker coatings and smaller tip hole sizes with thinner coatings.
- Tips wear with use and need periodic replacement.
- Tip hole size controls flow rate - the amount of paint that comes out of the gun.

FAN WIDTH

Fan width is the size of the stripe pattern, which determines the area covered with each stroke.

Hints:

- Select a fan width suited to the surface being sprayed.
- Wider fans allow provide better coverage on broad, open surfaces.
- Narrower fans provide better control on small, confined surfaces.

UNDERSTANDING TIP NUMBER

The last three digits of the tip number contain information about hole size and fan width on surface when gun is held 6 in. (15.2 cm) from surface being sprayed.

Rac5 tips are measured at 6 in. (15.2 cm) from surface.

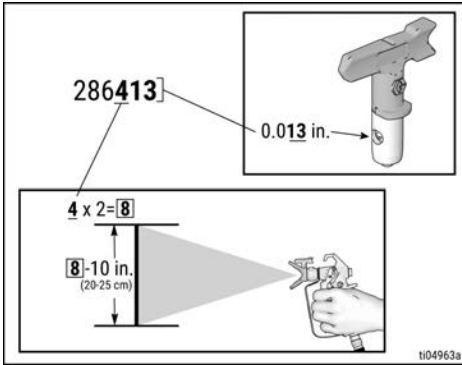

CLEAR TIP CLOG



If particles or debris clog the sprayer, the Reversible Spray Tip quickly and easily clears the clog, without the need to disassemble the sprayer.

See **Strain the Paint** for additional information.

1. Release trigger. Engage Trigger Lock. Rotate Reversible Spray Tip to unclog position. Disengage Trigger Lock. Trigger Airless Spray Gun at waste area to clear clog.

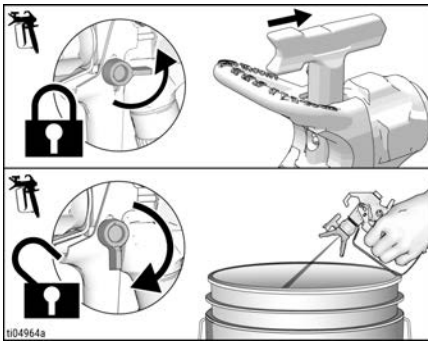

2. Engage Trigger Lock. Rotate Reversible Spray Tip back to spray position. Disengage Trigger Lock and continue spraying.

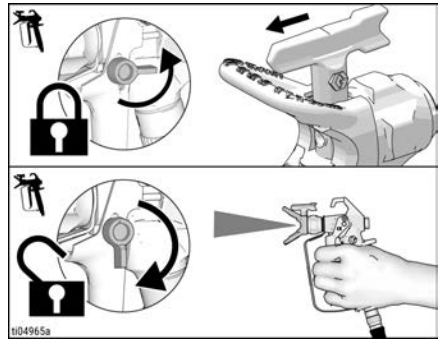

DIGITAL DISPLAY



OPERATION MAIN MENU

A short press of the Display Button moves to the next display. Press and hold Display Button for 10 seconds to change units or 2 seconds to reset data.

1. Perform **Pressure Relief Procedure**.
2. Install battery. See **Battery Installation and Removal**. Turn Power Button to **ON** position.

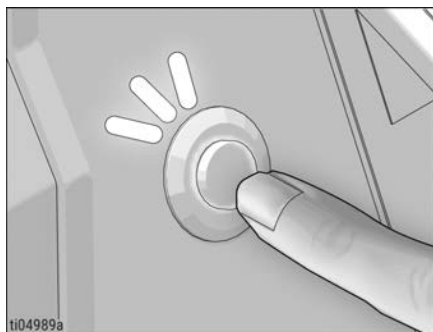

ti04989a

3. Pressure display appears. Dashes appear when pressure is less than 200 psi (1.4 MPa, 14 bar).

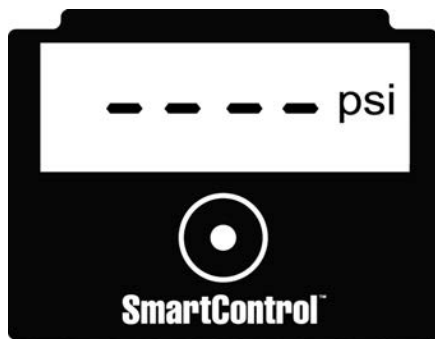

ti03424a

4. Short press Display Button to move to Job Gallons (or Liters x 10).

NOTE:

JOB displays briefly, then the number of gallons sprayed outside of FastFlush™.

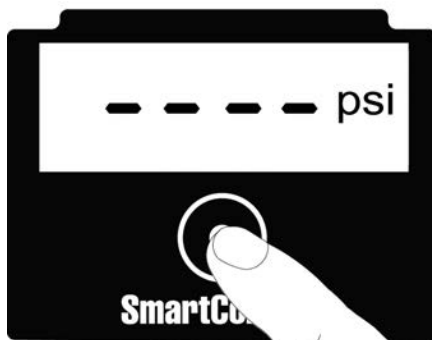

ti03425a

5. Press and hold Display Button to reset to zero, or short press button to move to Lifetime Gallons (or Liters x 10).

NOTE:

LIFE displays briefly, then the number of gallons sprayed outside of FastFlush™.

OPERATION

- To change pressure units (psi, MPa, or bar), press and hold Display Button for 10 seconds until desired units appear. Selection of MPa or bar changes gallons to Liters x 10.

NOTE:

This only works when pressure is displayed. Pressure units are displayed on right side of display.

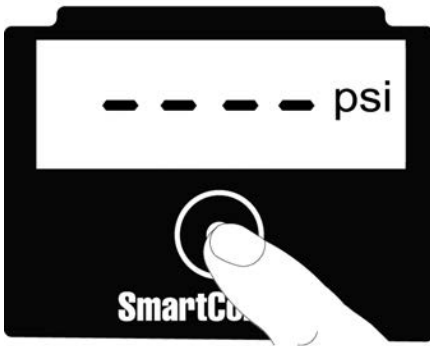

ti03426a

FASTFLUSH

The models are equipped with FastFlush, a high-flow cleaning system. To activate FastFlush, turn the Pressure Control knob to the FastFlush setting. You will feel a noticeable detent in the knob, and FLUSH will flash on the display when FastFlush is engaged.

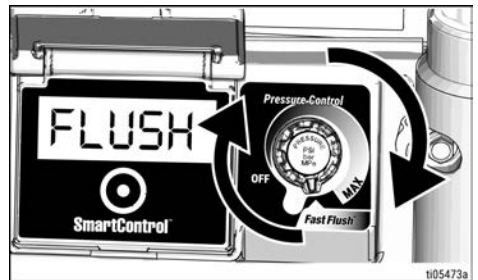

NOTE:

FastFlush is specifically designed to clean the internal components of the sprayer and should only be used with flushing fluids, such as water or mineral spirits. When in FastFlush, the sprayer will not spray paint or other materials.

STORED DATA DISPLAY

- Perform **Pressure Relief Procedure**.

OPERATION

2. Press and hold Display Button while turning the Power Button to **ON** position.

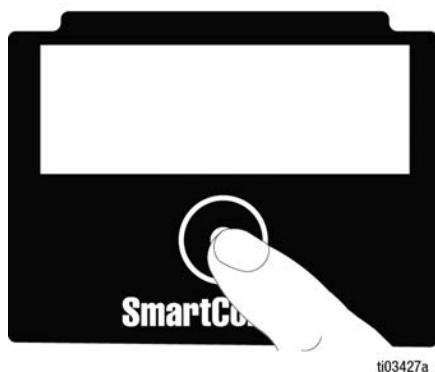

NOTE:

SERIAL CODE displays briefly, then the serial number.



3. Short press Display Button to see motor data.

NOTE:

MOTOR displays briefly, then the total motor run hours is displayed.

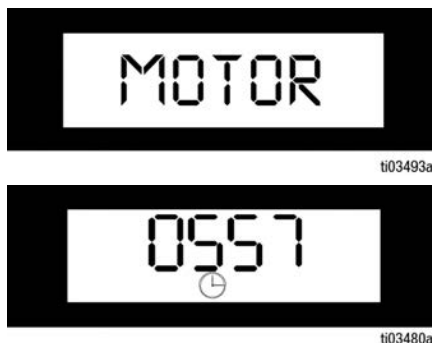

4. Short press Display Button and the last error code is displayed: e.g., **E=03**. See **Electrical** for troubleshooting information.



OPERATION

5. Press and hold Display Button to clear error code to NONE.



ti03430a

6. Short press Display Button to move to motor controller software rev.
7. Short press Display Button to move to display software rev.
8. Short press Display Button to move to sprayer ID.
9. Short press Display Button to move to **Knob Calibration** and **Transducer Calibration**.

10. Turn Power Button to **OFF** to exit Stored Data.

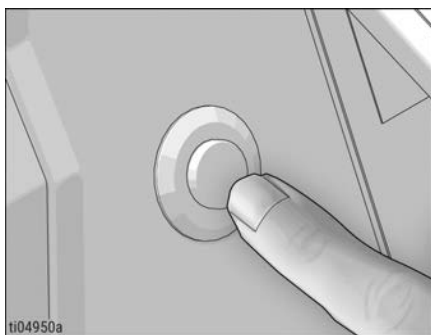

ti04950a

KNOB CALIBRATION

NOTE:

Knob calibration should be performed whenever a new Pressure Control knob is installed or the control board is replaced.

1. To perform knob calibration, enter secondary menu by holding Display Button while the sprayer is powered on.
2. Use Display Button to navigate to knob calibration screen.



ti03484a

OPERATION

3. Set Pressure Control knob to max spray position, just before FastFlush.



4. Press and hold Display Button until display shows PASS.
5. Turn Pressure Control knob back to the OFF position before restarting and reusing the sprayer.

4. Make sure Prime Valve is down to the prime position and there is no pressure in the sprayer.
5. Press and hold Display Button until display shows PASS.



TRANSDUCER CALIBRATION

NOTE:

Perform transducer calibration whenever a new transducer is installed or the control board is replaced.

1. Perform **Pressure Relief Procedure**.
2. To perform transducer calibration, enter secondary menu by holding Display Button while the sprayer is powered on.
3. Use Display Button to navigate to 0 (zero) calibration screen.



CLEANUP

| ⚠ WARNING | | | | |
|--|---|---|---|--|
|  |  |  |  | |

Clean the FieldLazer after each use for a trouble-free startup for the next time your sprayer is used.

1. Perform **Pressure Relief Procedure**.
2. Remove Tip Guard and spray, see **Spray Tip Installation**.

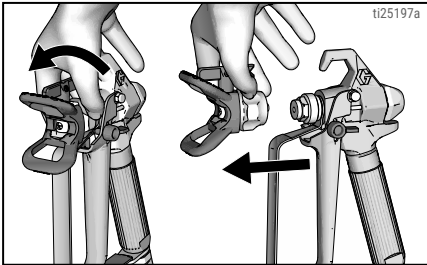

3. Remove Suction Tube and Drain Tube from paint and wipe excess paint off outside.

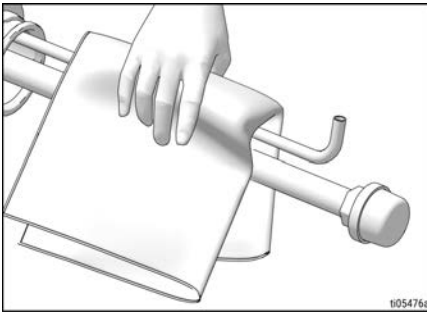

4. Separate Drain Tube (smaller) from Suction Tube (larger).

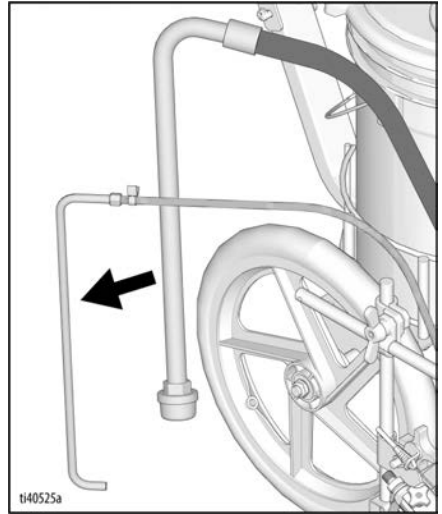

5. Place empty waste and water pails side by side.



CLEANUP

6. Place Suction Tube in water and Drain Tube in waste pail.

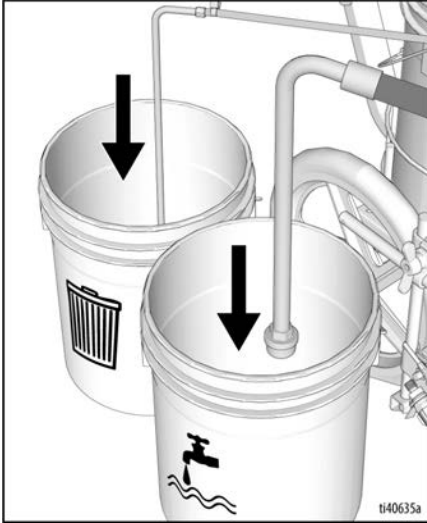

7. Turn the Pressure Control knob to the FastFlush setting.

NOTE:

You will feel noticeable detent in the knob, and FLUSH will flash on the display when the FastFlush is engaged. See **FastFlush** for additional information.

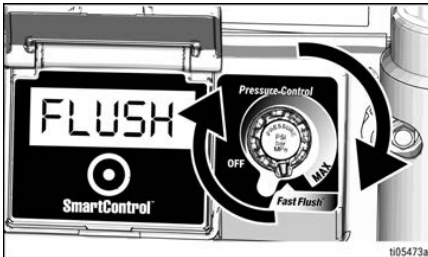

8. Place Prime Valve in prime position.

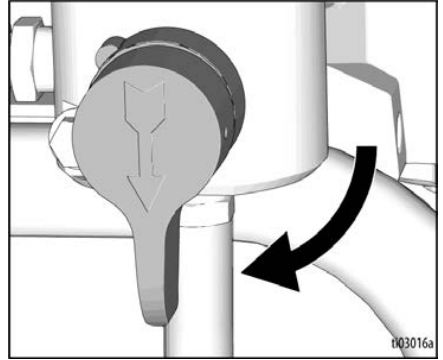

9. Press the Power Button to power **ON**. Power Button is illuminated when ON.
10. Flush until approximately 1/3 of the water is emptied from the pail or the fluid is clear.
11. Press the Power Button to power **OFF**. Power Button is not illuminated when OFF.

NOTE:

Step 12 is for returning paint in airless paint hose to paint pail. One 25 ft (7.5 m) hose holds approximately 1/2 qt (0.5 l) of paint.

12. To recover paint in hose:
- Hold Airless Spray Gun firmly.
 - Point Airless Spray Gun into paint pail.
 - Disengage Trigger Lock.
 - Pull and hold Airless Spray Gun trigger.

- e. Place Prime Valve in spray position.

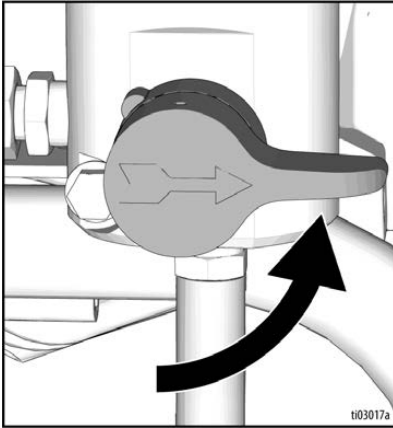

- f. Press Power Button to power **ON**. Power Button is illuminated when ON.
- g. Continue to hold Airless Spray Gun trigger until you see paint diluted with water starting to come out of Airless Spray Gun.

13. While continuing to trigger Airless Spray Gun, quickly move Airless Spray Gun to redirect spray into a waste pail. Continue triggering Airless Spray Gun into waste pail until flushing fluid dispensed from Airless Spray Gun is relatively clear.

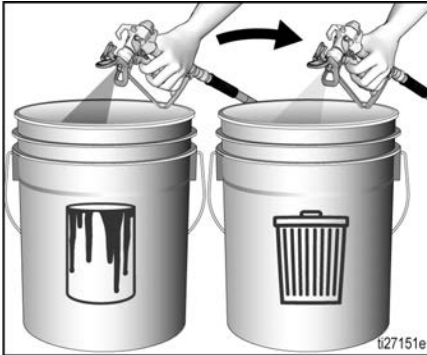

14. Stop triggering Airless Spray Gun. Engage the Trigger Lock.

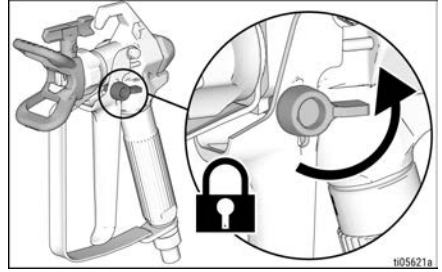

15. Place Prime Valve in prime position.

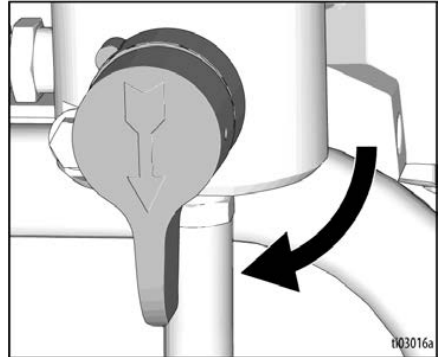

16. Press Power Button to power **OFF**. Power Button is not illuminated when OFF.

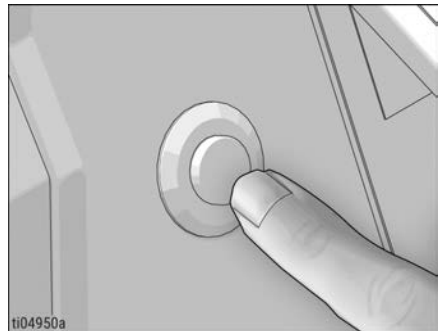

- Remove fluid filter if installed. Clean and inspect. Install new fluid filter if damage is present.

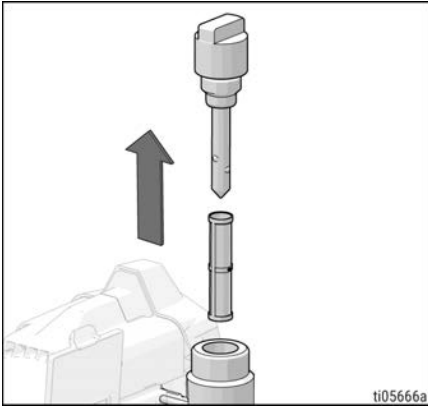

ti05666a

- Clean the Airless Spray Gun, see **Clean the Gun**. Reference separate gun manual for additional information. See **Related Manuals**.
- Fill unit with Pump Armor fluid to leave a protective coating to prevent freezing or corrosion.
- Remove battery. See **Battery Installation and Removal**.
- Wipe sprayer, Airless Hose, and Airless Spray Gun.

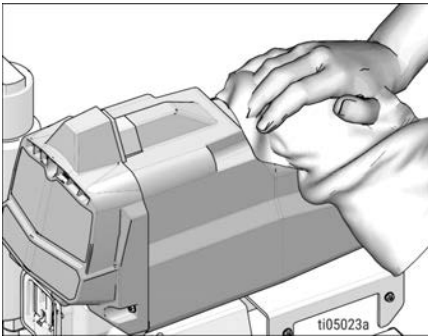

ti05023a

FAST FLUSH

The FieldLazer is equipped with FastFlush, a high-flow cleaning system that lets you clean your sprayer twice as fast while using half of the cleaning fluid. To activate FastFlush, turn the Pressure Control knob to the FastFlush setting. You will feel a noticeable detent in the knob, and FLUSH will flash on the display when FastFlush is engaged.

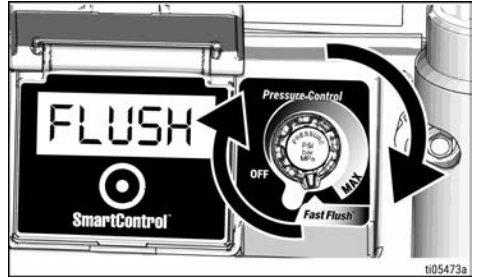

ti05473a

NOTE:

FastFlush is specifically designed to clean the internal components of the sprayer and should only be used with flushing fluids, such as water or mineral spirits. When FastFlush is activated, the sprayer will not spray paint or other materials.

CLEAN THE GUN

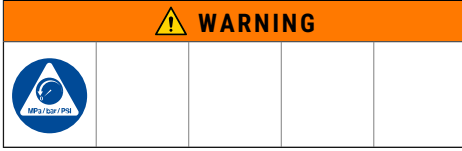

1. Perform **Pressure Relief Procedure** and remove the battery. See **Battery Installation and Removal**.
2. If optional Gun Fluid Filter is installed, clean Gun Fluid Filter with water or flushing fluid and a brush every time you flush the system. Replace Gun Fluid Filter if damaged.

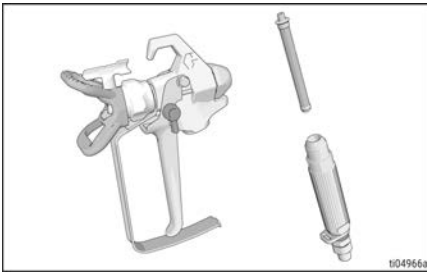

3. Remove Reversible Spray Tip and Tip Guard assembly and clean with water or flushing fluid and a brush.

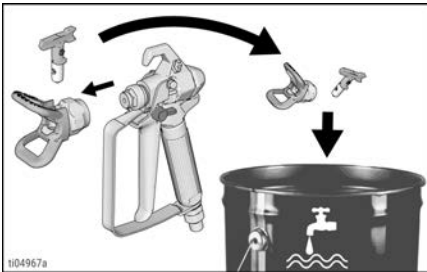

4. Wipe paint off outside of Airless Spray Gun using a soft cloth moistened with water or flushing fluid.

MAINTENANCE

Routine maintenance is important to ensure proper operation of the FieldLazer™ ES100. Maintenance includes performing routine actions that keep your sprayer in operation and prevent trouble in the future.



| ACTIVITY | INTERVAL |
|--|----------------------------------|
| Inspect/clean sprayer filter, Fluid Intake Strainer, and Gun Fluid Filter. | Daily or each time you spray |
| Inspect motor shield vents for blockage. | Daily or each time you spray |
| Fill TSL by adding through TSL fill point. | Daily or each time you spray |
| <p>Check sprayer stall.</p> <p>With Airless Spray Gun NOT triggered, sprayer motor should stall and not restart until Airless Spray Gun is triggered again.</p> <p>If sprayer starts again with Airless Spray Gun NOT triggered, inspect Pump for internal/external leaks and check Prime Valve for leaks.</p> | Every 1000 gallons (3785 liters) |
| <p>Throat packing adjustment.</p> <p>When pump packing begins to leak after extended use, tighten packing nut down until leakage stops or lessens. This allows approximately 100 gallons of additional operation before a repacking is required. Packing nut can be tightened without O-ring removal.</p> | As necessary based on usage |

END OF PRODUCT LIFE

At the end of the product's useful life, dismantle and recycle it in a responsible manner.

- Perform the **Pressure Relief Procedure**.
- Drain and dispose of fluids according to applicable regulations. Refer to the material manufacturer's Safety Data Sheet.
- Remove motors, batteries, circuit boards, LCDs (liquid crystal displays), and other electronic components. Recycle according to applicable regulations.
- Do not dispose of batteries or electronic components with household or commercial waste. 
- Deliver remaining product to a recycling facility.

TROUBLESHOOTING

When problems occur, use the table to identify potential causes and solutions to repair the FieldLazer™ ES100.

2. Check all possible problems and causes before disassembling the unit.

MECHANICAL/FLUID FLOW

|  WARNING | | | | |
|---|---|---|---|---|
|  |  |  |  |  |
| <p>To help prevent serious injury from pressurized fluid, such as skin injection, splashing fluid, and moving parts, follow the Pressure Relief Procedure when you stop spraying and before cleaning, checking, or servicing the equipment.</p> <p>Keep clear of moving parts during troubleshooting procedures.</p> | | | | |

1. Follow **Pressure Relief Procedure** before checking or repairing.

| PROBLEM | CAUSE | SOLUTION |
|--|---|---|
| Motor does not run: Verify battery is correctly installed and fully charged, and Power Button is on. | Pressure Control knob is set at zero pressure. | Turn Pressure Control knob clockwise to increase pressure setting. |
| | Pump is seized. (Paint has hardened in pump or water is frozen in pump). | Turn Power Button off and remove battery. If frozen do NOT try to start sprayer until it is completely thawed or it may damage the motor, control board and/or drive train. Place sprayer in warm area for several hours. If not frozen, check for hardened paint in pump. |
| Pump output is low or poor spray pattern. | Spray Tip is worn. | Replace Spray Tip. See separate gun or tip manual. |
| | Spray Tip is clogged. | Relieve pressure. Check and clean Spray Tip. See Clear Tip Clog . |
| | Fluid Intake Strainer is clogged. | Remove and clean, then reinstall. |

TROUBLESHOOTING

| PROBLEM | CAUSE | SOLUTION |
|--|--|--|
| | Intake valve ball and piston ball are not seating properly. | Remove intake valve and clean. Check balls and seats for nicks; replace as necessary. See pump manual. Strain paint before using to remove particles that could clog Pump. |
| | Fluid filter or tip filter is clogged or dirty. | Clean filter. |
| | Prime Valve is leaking. | Replace Prime Valve. |
| | Verify Pump does not continue to stroke when Airless Spray Gun trigger is released. (Prime Valve not leaking.) | Service Pump. See pump manual. |
| | Leaking around throat packing nut, which may indicate worn or damaged packings. | Replace packings. See pump manual. Also check piston valve seat for hardened paint or nicks and replace if necessary. Tighten packing nut/wet-cup. |
| Pump output is low. | Large pressure drop in hose with heavy materials. | Reduce overall length of hose. |
| | Pump rod is damaged. | Repair Pump. See pump manual. |
| | Low stall pressure. | Turn Pressure Control knob fully clockwise. Make sure Pressure Control knob is properly installed to allow full clockwise position. Perform Knob Calibration . If problem persists, replace Pressure Control. |
| | Piston packings are worn or damaged. | Replace packings. See pump manual. |
| Excessive paint leakage into throat packing nut. | Throat packing nut is loose. | Remove throat packing nut spacer. Tighten throat packing nut just enough to stop leakage. |
| | Throat packings are worn or damaged. | Replace packings. See pump manual. |
| | Displacement rod is worn or damaged. | Replace rod. See pump manual. |







TROUBLESHOOTING

| PROBLEM | CAUSE | SOLUTION |
|---|--|---|
| Fluid is spitting from Airless Spray Gun. | Air in Pump or hose. | Check and tighten all fluid connections. Cycle Pump as slowly as possible during priming. |
| | Reversible Spray Tip is partially clogged. | Clear tip. See Clear Tip Clog . |
| | Fluid supply is low or empty. | Refill fluid supply. Prime Pump. See pump manual. Check fluid supply often to prevent running Pump dry. |
| Pump is difficult to prime. | Air in Pump or hose. | Check and tighten all fluid connections. Cycle Pump as slowly as possible during priming. |
| | Intake valve is leaking. | Clean intake valve. Be sure ball seat is not nicked or worn and that ball seats well. Reassemble valve. |
| | Pump packings are worn. | Replace pump packings. See pump manual. |
| | Paint is too thick. | Thin the paint according to supplier recommendations. |

ELECTRICAL

Use the table to identify potential causes and solutions when the sprayer does not run, stops running, or will not shut off.

1. Perform **Pressure Relief Procedure**.
2. Turn the Power Button to **OFF**, wait 30 seconds and then turn power back **ON** again.
3. Turn Pressure Control knob clockwise 1/2 turn.

|  WARNING | | | | |
|---|---|---|---|---|
|  |  |  |  |  |
| <p>To help prevent serious injury from pressurized fluid, such as skin injection, splashing fluid, and moving parts, follow the Pressure Relief Procedure when you stop spraying and before cleaning, checking, or servicing the equipment.</p> <p>Keep clear of moving parts during troubleshooting procedures.</p> | | | | |

| PROBLEM | CAUSE | SOLUTION |
|--|--|---|
| Motor does not run: Verify battery is correctly installed and fully charged, and Power Button is on. | Battery has insufficient charge. | Charge battery. |
| | Battery is defective. | Replace battery. |
| | Motor control is damaged. | Consult a Graco authorized retailer, distributor, or service center. |
| Sprayer does not run at all. | Check Pressure Control connections. | Make certain connector is clean and firmly connected. |
| | Check Pressure Control. | Connect known good Pressure Control. If the motor runs, replace Pressure Control. |
| | Check motor leads. | Make certain terminals are clean and firmly connected. |
| Sprayer has an error. | Check Sprayer Error Code Messages . | See Sprayer Error Code Messages . |
| Pressure reading is erratic. | Transducer connection may be wet. | Unplug and allow transducer to dry. |
| Battery Management System has an error. | Check error code messages for Battery Management System. | See Error Code Messages - Battery Management System . |

TROUBLESHOOTING

SPRAYER ERROR CODE MESSAGES

| CODE | MESSAGE | ACTION |
|-------|---|---|
| 02 | Code 02 - High pressure detected | Relieve pressure. Check for clogs in filters and hoses. Use minimum 25 ft (8 m) of Graco hose. Check transducer. |
| 03 | Code 03 - Pressure transducer not detected | Turn sprayer OFF and remove battery from the sprayer. Remove shroud. Check transducer cable and connection to control board. Check transducer. |
| 04 | Code 04 - High Voltage | Turn sprayer OFF and remove the battery from the sprayer. Install fully charged approved battery to prevent damage to electronics. |
| 05 | Code 05 - Motor not spinning due to high mechanical load | Turn sprayer OFF and remove battery from the sprayer. Attempt to spin. Motor should spin freely. If motor does not spin easily, remove Pump and recheck by spinning motor again. If motor spins easily, check control board. |
| 06 | Code 06 - Motor thermal protection enabled | Allow time to cool. This may take up to an hour. Check vents in bottom and top of sprayer for blockage. Remove battery from the sprayer and check to make sure the motor spins freely. |
| 09 | Code 09 - Connection to hall board failed | Turn sprayer OFF and remove battery from the sprayer and wait 5 minutes. Remove shroud. Check cables and connections. Check motor. |
| 12 | Code 12 - Excessive current protection enabled | Cycle power ON and OFF . If problem persists, check motor. |
| 15 | Code 15 - Motor not spinning, no motor current detected | Turn sprayer OFF and remove battery from the sprayer and wait five minutes. Remove shroud. Check cables and connections. Check control board. Check motor. |
| 18 | Code 18 - Communication to expansion/display board failed | Turn sprayer OFF and remove battery from the sprayer and wait 5 minutes. Remove shroud. Check cables and connections. |
| 21 | Code 21 - Control board thermal protection enabled | Allow time to cool. This may take up to an hour. Check vents in bottom and top of sprayer for blockage. Remove battery from the sprayer and check to make sure the motor spins freely. |
| LOBAT | LOBAT - Incoming voltage too low for sprayer operation | Turn sprayer OFF and remove battery from the sprayer. Install fully charged approved battery to prevent damage to electronics. |

ERROR CODE MESSAGES - BATTERY MANAGEMENT SYSTEM

The ES100 Standard FieldLazer includes a Battery Management System (BMS), which is an electronic device to monitor and control use of the battery while power to the sprayer is ON. At any time the BMS may determine that the battery is operating outside of the allowed limits, in which case an error code consisting of a specific number of blink sequences will flash on the Power Button one time before the BMS turns off the power to the sprayer. One blink sequence consists of half a second off followed by half a second on blink of the Power Button. You can count the number of blink sequences to identify the BMS error code as described in the table.

TROUBLESHOOTING

| CODE (# OF BLINK SEQUENCES) | MESSAGE | ACTION |
|--|---|--|
| 1 | Power Button is mechanically stuck or electrically shorted in the ON state. | <p>Remove battery, then:</p> <ol style="list-style-type: none"> 1. Check for debris (dried paint, dirt, etc) that may be on the Power Button and gently clean if necessary. 2. Press Power Button two or three times to free it if stuck. 3. Replace Power Button if step 1 or 2 does not remedy the problem. |
| 2 | At least one cell of the battery is below the minimum allowed voltage. | Replace battery with a fully charged battery, and place the original battery on an approved charger. |
| 3 | Battery temperature is too high. | Replace battery with a fully charged battery, and let the original battery naturally cool. |
| 4 | Battery current draw is too high. | <ol style="list-style-type: none"> 1. Check for errors displayed for the sprayer (See Sprayer Error Code Messages). 2. Remove battery. Check for any obvious signs of damage to the sprayer, such as pinched wiring. |
| 5 | BMS self-test has failed. | Wait 10 seconds and retry. If multiple retries do not work, remove battery and check for any obvious signs of damage to the sprayer, such as pinched wiring. If no obvious problem is found, and the self-test failure persists, the BMS should be replaced. |
| None (Power Button cannot turn machine ON and button never illuminates). | | <ol style="list-style-type: none"> 1. Remove battery. 2. Replace with a fully charged battery, and try Power Button again. 3. If problem still persists with second battery, the BMS fuse has likely blown and BMS should be replaced (fuse is not serviceable; must replace entire BMS). |

FIELDLAZER™ ES100 PARTS

The parts illustration and list shows the components of the FieldLazer™ ES100 Parts and their connections that are required for assembly, repair, and maintenance.

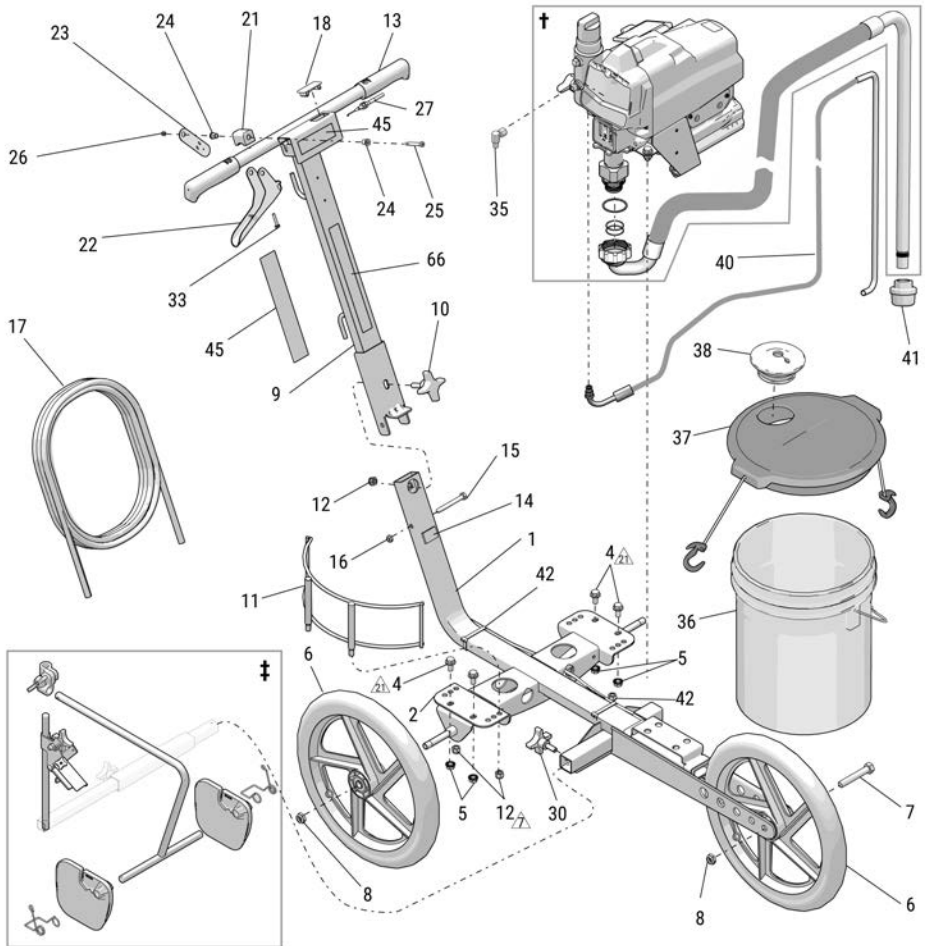

105671b

† See Motor Parts

‡ See Sprayer Shield Parts

Figure 14-1: FieldLazer™ ES100 Parts Parts Diagram

FIELDLAZER™ ES100 PARTS

| REF. | PART | DESCRIPTION | QTY. |
|------|---------|--------------------------------|------|
| 1 | 2011519 | FRAME, fieldmarker | 1 |
| 2 | 2013389 | AXLE, narrow | 1 |
| 4 | 112395 | SCREW, cap, flng hd | 4 |
| 5 | 112958 | NUT, hex, flanged, 3/8-16 | 4 |
| 6 | 119528 | TIRE, semi-pneumatic | 3 |
| 7 | 101147 | SCREW, cap, hex hd | 1 |
| 8 | 119547 | NUT, hex, lock, nylon, thin | 3 |
| 9 | 15F645 | HANDLE, fieldmarker | 1 |
| 10 | 108471 | KNOB, pronged | 1 |
| 11 | 15E955 | HOLDER, bracket | 2 |
| 12 | 101566 | NUT, lock | 5 |
| 13 | 116139 | GRIP, handle | 2 |
| 14 | 17P800 | BUMPER, 0.88 wide x 0.17 thk | 1 |
| 15 | 113664 | SCREW, cap, hex hd | 1 |
| 16 | 112746 | NUT, hex | 1 |
| 17 | 240793 | HOSE, coupled, 1/4 in. x 25 ft | 1 |
| 18 | 19D422 | COVER, plug, panel switch | 1 |
| 21 | 198896 | BLOCK, mounting (mach) | 1 |
| 22 | 245676 | HANDLE | 1 |
| 23 | 198895 | PLATE, lever, pivot | 1 |
| 24 | 111017 | BEARING, flange | 2 |
| 25 | 116941 | SCREW, shoulder, socket head | 1 |
| 26 | 129476 | NUT, lock | 1 |

| REF. | PART | DESCRIPTION | QTY. |
|------|---------|---|------|
| 27 | 119534 | CABLE, gun | 1 |
| 30 | 111145 | KNOB, pronged | 1 |
| 33 | 128803 | SCREW, 10-24 x 1.5 in., taptite, phil | 1 |
| 35 | 155541 | FITTING, swivel, 90 deg | 1 |
| 36 | 115077 | PAIL, plastic | 1 |
| 37 | 24U241 | KIT, pail cover | 1 |
| 38 | 278723 | GASKET, pail | 1 |
| 40 | 24V688 | HOSE, drain | 1 |
| 41 | 276897 | KIT, strainer, 7/8-14 | 1 |
| 42 | 404989 | STRAP, tie | 2 |
| 45▲ | 2013879 | Warning Label, US/NA | |
| | 2013891 | Warning Label, ANZ/AP | |
| | 19D437 | Warning Label, EMEA/UK | |
| 66 | 2014338 | LABEL, Field Lazer, handle | 1 |
| ▲ | 222385 | Medical Alert Card, US, CE, and UK models (not shown) | 1 |
| | 17A134 | Medical Alert Card, ANZ/KOR models (not shown) | |

▲ Replacement safety labels, tags, and cards are available at no cost.

FIELDLAZER™ ES100 PARTS

| REF. | PART | DESCRIPTION | QTY. |
|------|---------|--|------|
| 4 | 112395 | SCREW, cap, flng hd | 4 |
| 8 | 2014718 | KIT, motor, cordless | 1 |
| 9 | 2014619 | KIT, Control Board, ES100 | 1 |
| 10 | 2008839 | KIT, gears, <i>includes 10a</i> | 1 |
| 10a | | BEARING, thrust | |
| 11 | 24W817 | KIT, drive housing, <i>includes 10a</i> | 1 |
| 12 | 24W640 | KIT, connecting rod | 1 |
| 13 | 19D873 | KIT, pump, <i>includes 33, 34</i> | 1 |
| 14 | 24W830 | KIT, pump hose | 1 |
| 16 | 20B438 | KIT, suction hose | 1 |
| 19 | 2009888 | KIT, shroud, <i>includes 27, 49</i> | 1 |
| 20 | 2014740 | KIT, brand label, ES100 | 1 |
| 27 | 2001659 | SCREW, thread forming, torx pan hd | 9 |
| 32 | 2008855 | KIT, filter board shroud | 1 |
| 33 | 117117 | O-RING | 1 |
| 34 | 16N901 | O-RING | 2 |
| 35 | 16H137 | O-RING | 1 |
| 37 | 117493 | SCREW, mach, hex washer hd, 1/4-20 x 1.5 in. | 4 |
| 38 | 2014720 | Kit, BMS | 1 |
| 42 | 2013432 | BRACKET, pump, painted | 1 |

| REF. | PART | DESCRIPTION | QTY. |
|------|---------|---|------|
| 45 | 127914 | SCREW, mach, slot hex wash hd, #8-32 x 0.75 in. | 3 |
| 46 | 112774 | SCREW, mach, sltd hex wash hd, 1/4-20 x 0.625 in. | 4 |
| 48 | 2013688 | PLATE, retainer, bms, painted | 1 |
| 49 | | SCREW, #8-16 plastite | 1 |
| 56 | 2008046 | Wire Harness | 1 |

FILTER PARTS

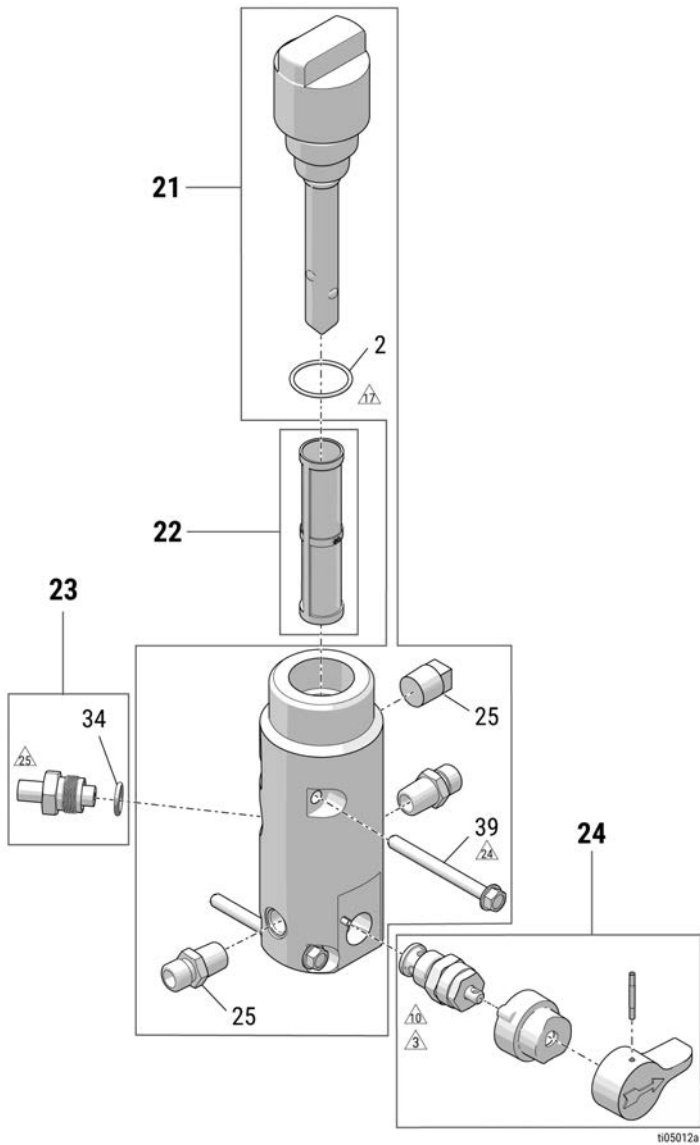
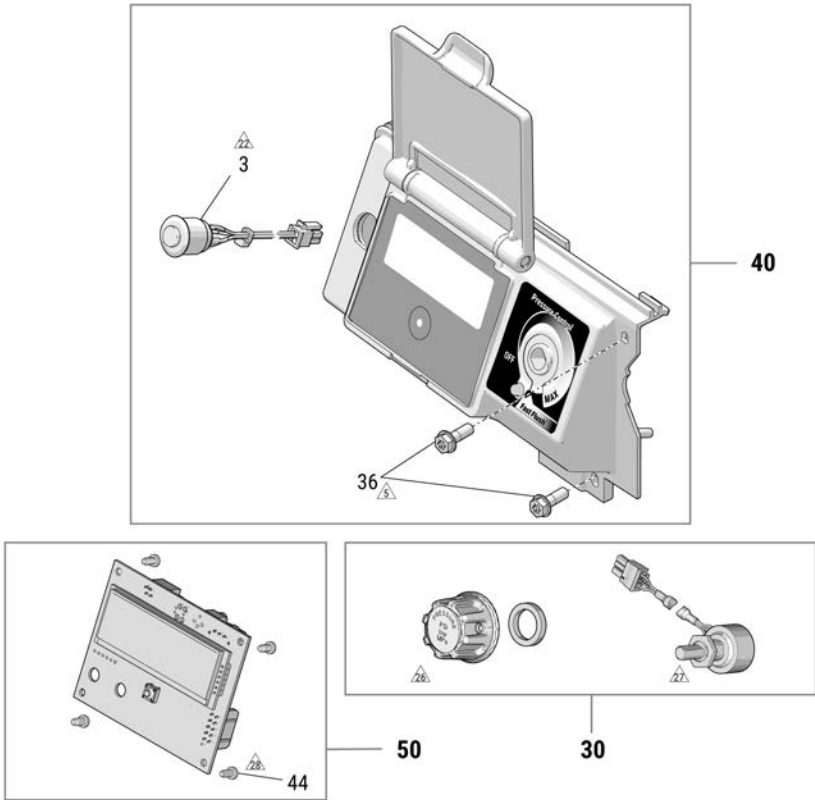

Figure 14-3: Filter Parts Diagram

FIELDLAZER™ ES100 PARTS

| REF. | PART | DESCRIPTION | QTY. |
|------|---------|---|------|
| 2 | 117828 | KIT, o-ring, PTFE encapsulated | 1 |
| 21 | 2014738 | KIT, filter manifold | 1 |
| 22 | 246384 | KIT, repair, filter, 60 mesh | 1 |
| | 246425 | KIT, repair, filter, 30 mesh | 1 |
| | 246382 | KIT, repair, filter, 100 mesh | 1 |
| 23 | 287172 | KIT, repair, transducer, <i>includes 34</i> | 1 |
| 24 | 235014 | KIT, drain valve | 1 |
| 25 | 162453 | FITTING, 1/4 npsm x 1/4 npt | 2 |
| 34 | 111457 | O-RING | 1 |
| 39 | 119525 | SCREW, thread forming, 1/4-20 x 2.5 in. | 2 |

SIDE SHROUD ASSEMBLY PARTS



1105013a

Figure 14-4: Side Shroud Assembly Parts Diagram

FIELDLAZER™ ES100 PARTS

| REF. | PART | DESCRIPTION | QTY. |
|------|---------|---|------|
| 3 | 2011020 | Power Button Replacement | 1 |
| 30 | 20B425 | KIT, potentiometer | 1 |
| 36 | 2001659 | SCREW, thread forming, torx pan hd | 4 |
| 40 | 2014719 | KIT, side shroud, <i>includes 30, 36 (4x), 49</i> | 1 |
| 44 | 115522 | SCREW, mach, pnh, #4-20 x 0.25 in. | 4 |
| 49 | | SCREW, #8-16 plastite (not shown) | 1 |
| 50 | 2008840 | KIT, display board | 1 |

SPRAYER SHIELD PARTS

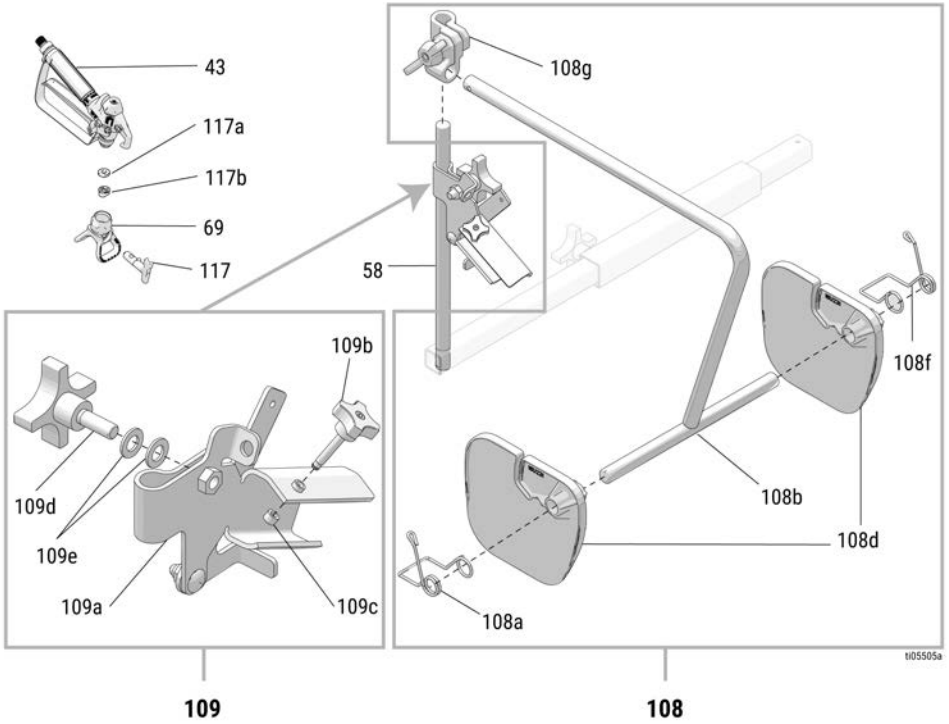

















Figure 14-5: Sprayer Shield Parts Diagram

FIELDLAZER™ ES100 PARTS

| REF. | PART | DESCRIPTION | QTY. |
|------|--------|---|------|
| 43 | 243011 | KIT, gun, spray, SG2, <i>includes optional filter 288749</i> | 1 |
| 58 | 287453 | BRACKET, support, extension | 1 |
| 69 | 243161 | KIT, guard, RAC 5 | 1 |
| 108 | 249081 | KIT, spray shield, <i>includes 108a - 108g</i> | 1 |
| 108a | 15F142 | GUIDE, wire, right shield | 1 |
| 108b | 287494 | BAR, guide shield | 1 |
| 108d | 16U231 | SHIELD, guide | 2 |
| 108f | 15F143 | GUIDE, wire, left shield | 1 |
| 108g | 287566 | KIT, clamp | 1 |
| 109 | 287529 | KIT, gun holder | 1 |
| 109a | | GUN HOLDER | 1 |
| 109b | 119619 | KNOB | 1 |
| 109c | 119666 | PAD, swivel | 1 |
| 109d | 111145 | KNOB, pronged | 1 |
| 109e | 112914 | WASHER, plain | 2 |
| 117 | LL5421 | TIP, spray RAC 5, striping, <i>includes 117a, 117b</i> | 1 |
| 117a | 115524 | GASKET | 1 |
| 117b | 195558 | SEAT, cylinder | 1 |

TORQUE SPECIFICATIONS

| | |
|--|--|
|  | 18 - 22 in-lbs (2 - 2.5 N·m) |
|  | Apply sealant to threads |
|  | 150 ± 10 in-lbs (15.8 - 18.1 N·m) |
|  | 28 - 32 in-lbs (3.2 - 3.6 N·m) |
|  | 70 ± 5 ft-lbs (88.9 - 95.6 N·m) (locking ring on pump) |
|  | 100 ± 10 in-lbs (10.2 - 12.4 N·m) |
|  | 140 ± 3 in-lbs (15.4 - 16.2 N·m) |
|  | Apply lubricant to o-ring |
|  | 19 ± 2 ft-lbs (23 - 28.5 N·m) |
|  | 6 - 8 in-lbs (0.7 - 0.9 N·m) |
|  | 120 ± 10 in-lbs (12.4 - 14.7 N·m) |
|  | 40 ± 3 ft-lbs (50.2 - 56.3 N·m) |
|  | 12 - 14 in-lbs (1.4 - 1.6 N·m) |
|  | 8 - 10 in-lbs (0.9 - 1.1 N·m) |
|  | 2 - 4 in-lbs (0.2 - 0.5 N·m) |

ELECTRICAL SCHEMATIC

The wiring diagram illustrates the electronic connections that are useful for troubleshooting and repairing the electrical components of the FieldLazer™ ES100 Parts.

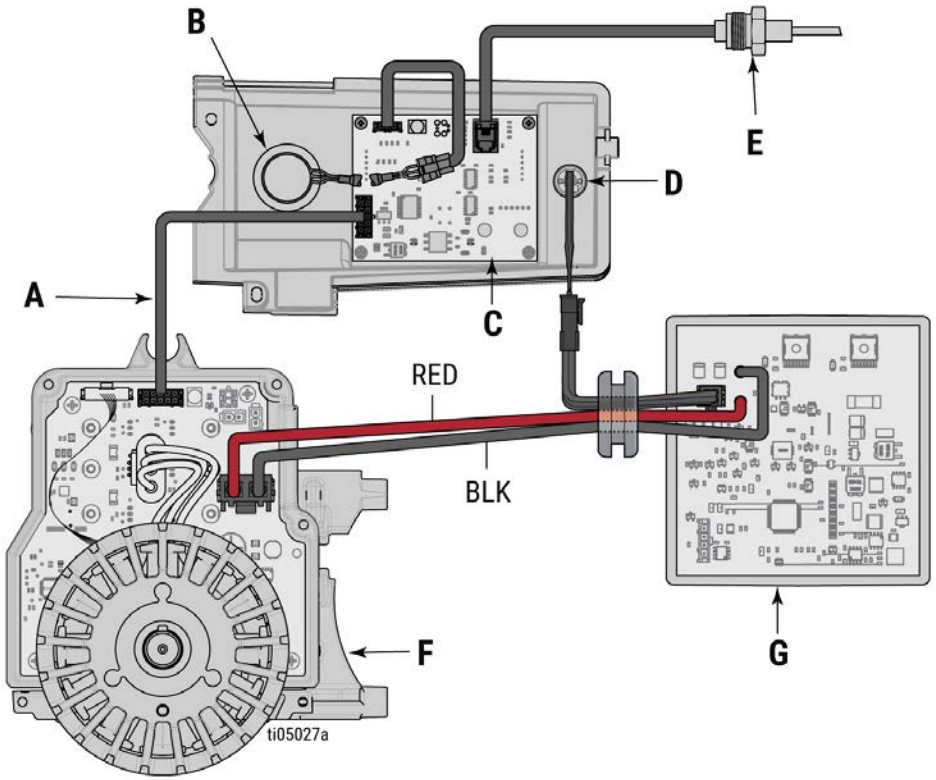

Figure 15-1: Wiring Diagram for the FieldLazer™ ES100 Parts

KEY

| | |
|-----|---|
| A | Motor Controller to Display Board Communication Cable |
| B | Pressure Control |
| C | Display Board |
| D | Power Button |
| E | Pressure Transducer |
| F | Motor Controller |
| G | Battery Management System (BMS) |
| BLK | Black |
| RED | Red |

CALIFORNIA PROPOSITION 65

CALIFORNIA RESIDENTS



WARNING Cancer and reproductive harm – www.P65warnings.ca.gov.

GRACO STANDARD WARRANTY

Graco warrants all equipment referenced in this document which is manufactured by Graco and bearing its name to be free from defects in material and workmanship on the date of sale to the original purchaser for use. With the exception of any special, extended, or limited warranty published by Graco, Graco will, for a period of twelve months from the date of sale, repair or replace any part of the equipment determined by Graco to be defective. This warranty applies only when the equipment is installed, operated and maintained in accordance with Graco's written recommendations.

This warranty does not cover, and Graco shall not be liable for general wear and tear, or any malfunction, damage or wear caused by faulty installation, misapplication, abrasion, corrosion, inadequate or improper maintenance, negligence, accident, tampering, or substitution of non-Graco component parts. Nor shall Graco be liable for malfunction, damage or wear caused by the incompatibility of Graco equipment with structures, accessories, equipment or materials not supplied by Graco, or the improper design, manufacture, installation, operation or maintenance of structures, accessories, equipment or materials not supplied by Graco.

This warranty is conditioned upon the prepaid return of the equipment claimed to be defective to an authorized Graco distributor for verification of the claimed defect. If the claimed defect is verified, Graco will repair or replace free of charge any defective parts. The equipment will be returned to the original purchaser transportation prepaid. If inspection of the equipment does not disclose any defect in material or workmanship, repairs will be made at a reasonable charge, which charges may include the costs of parts, labor, and transportation.

THIS WARRANTY IS EXCLUSIVE, AND IS IN LIEU OF ANY OTHER WARRANTIES, EXPRESS OR IMPLIED, INCLUDING BUT NOT LIMITED TO WARRANTY OF MERCHANTABILITY OR WARRANTY OF FITNESS FOR A PARTICULAR PURPOSE. Graco's sole obligation and buyer's sole remedy for any breach of warranty shall be as set forth above. The buyer agrees that no other remedy (including, but not limited to, incidental or consequential damages for lost profits, lost sales, injury to person or property, or any other incidental or consequential loss) shall be available. Any action for breach of warranty must be brought within two (2) years of the date of sale.

GRACO MAKES NO WARRANTY, AND DISCLAIMS ALL IMPLIED WARRANTIES OF MERCHANTABILITY AND FITNESS FOR A PARTICULAR PURPOSE, IN CONNECTION WITH ACCESSORIES, EQUIPMENT, MATERIALS OR COMPONENTS SOLD BUT NOT MANUFACTURED BY GRACO. These items sold, but not manufactured by Graco (such as electric motors, switches, hose, etc.), are subject to the warranty, if any, of their manufacturer. Graco will provide purchaser with reasonable assistance in making any claim for breach of these warranties.

In no event will Graco be liable for indirect, incidental, special or consequential damages resulting from Graco supplying equipment hereunder, or the furnishing, performance, or use of any products or other goods sold hereto, whether due to a breach of contract, breach of warranty, the negligence of Graco, or otherwise.

FOR GRACO CANADA CUSTOMERS The Parties acknowledge that they have required that the present document, as well as all documents, notices and legal proceedings entered into, given or instituted pursuant hereto or relating directly or indirectly hereto, be drawn up in English. Les parties reconnaissent avoir convenu que la rédaction du présente document sera en Anglais, ainsi que tous documents, avis et procédures judiciaires exécutés, donnés ou intentés, à la suite de ou en rapport, directement ou indirectement, avec les procédures concernées.

GRACO INC. AND SUBSIDIARIES | P.O. BOX 1441 | MINNEAPOLIS MN 55440-1441 | USA

Graco Headquarters: Minneapolis, MN USA | International Offices: Australia, Belgium, China, Japan, Korea | Toll Free Phone Number: 1-800-690-2894 (Contractor Division) and 1-800-328-0211 (Industrial Division) | For patent information, see graco.com/patents

©2025 Graco Inc. All written and visual data in this document are based on the latest product information available at the time of publication. Graco reserves the right to make changes at any time without notice. All Graco manufacturing locations maintain ISO 9001:2015 certifications, each certified by accredited certification bodies. Original Instructions. This manual contains English. Revision A, December 2025